

# JACO

RESEARCH EDITION



SPECIFICATIONS

## MECHANICAL

TOTAL WEIGHT	5,7 kg
MAXIMUM PAYLOAD	1,5 kg mid-range 1,0 kg full extension
MAXIMUM REACH	90 cm
GEAR SYSTEM	
<i>Type</i>	Harmonic Drive™
<i>Resolution</i>	1:100
<i>Back drivability</i>	When shutdown
ABSOLUTE POSITION TOLERANCE	8 mm
RELATIVE POSITION TOLERANCE	1,6 mm
MAXIMUM LINEAR ARM SPEED	15 cm/s (Cartesian)
AMBIENT TEMPERATURE	0°C to 30°C
WATER RESISTANCE	IPX2 rating

## ELECTRONIC

UTILIZATION VOLTAGE	18VDC to 29VDC
AVERAGE CURRENT (NORMAL USE)	1,7 A
AVERAGE POWER (NORMAL USE)	40 W
CONTROL SYSTEM FREQUENCY	100 Hz
CPU	270 Mhz
USB 2.0	
CANBUS	
<i>Transfer speed</i>	1 Mb/sec
SLIP RING	
<i>Location</i>	1 in every joint
EXPANSION CARD	
<i>Connector</i>	2 expansion cards connectors
<i>Protocol</i>	SPI
<i>2 expansion wires through external joystick connector</i>	
<i>2 expansion wires through internal of the arm</i>	

## FIRMWARE

EACH AXIS CONTROLLED INDEPENDENTLY

REDUNDANT SECURITY ON EACH AXIS / FINGERS

REDUNDANT ERROR CHECK IN JOINTS AND IN CONTROL SYSTEM

POSITION AND ERROR CALCULATION EVERY 0.01 SECOND

SINGULARITY AVOIDANCE SYSTEM

CARTESIAN AND ANGULAR TRAJECTORY CONTROL

## ACTUATORS - Large actuator

QUANTITY	3
DIMENSIONS	
<i>Diameter</i>	74.5 (+0.00 / -0.030) mm
<i>Height</i>	67mm max
<i>Input fixation type</i>	8X M4 screws (5mm deep)
<i>Output fixation type</i>	8X M4 screws (5mm deep)
TOTAL WEIGHT	0.64 Kg +/-2%
ABSOLUTE POSITION	+/- 0.5 degree
RELATIVE POSITION	+/- 0.05 degree
MOTOR TYPE	Brushless DC motor
NUMBER OF TURNS	+/- 13.5 turns
TEMPERATURE <i>Maximum</i>	75°C continuous
VELOCITY <i>Maximum</i>	8 RPM
COMMAND/SEC <i>Maximum</i>	48 °/sec
UTILIZATION VOLTAGE	18VDC to 29VDC
TORQUE	
<i>Continuous</i>	15 Nm
<i>Peak</i>	26 Nm

## ACTUATORS - Small Joint

QUANTITY	3
DIMENSIONS	
<i>Diameter</i>	58 (+0.00 / -0.030) mm
<i>Height</i>	69mm max
<i>Input fixation type</i>	6X M3 screws (5mm deep)
<i>Output fixation type</i>	6X M3 screws (5mm deep)
TOTAL WEIGHT	0.39Kg +/- 2%
ABSOLUTE POSITION	+/- 0.5 degree
RELATIVE POSITION	+/- 0.075 degree
MOTOR TYPE	Brushless DC motor
NUMBER OF TURNS	+/- 13.5 turns
TEMPERATURE <i>Maximum</i>	75°C continuous
VELOCITY <i>Maximum</i>	10 RPM
COMMAND/SEC <i>Maximum</i>	60 °/sec
UTILIZATION VOLTAGE	18VDC to 29VDC
TORQUE	
<i>Continuous</i>	4 Nm
<i>Peak</i>	7 Nm

## ACTUATORS - Finger actuator

QUANTITY	3
MOTOR TYPE	Brushless DC motor
TEMPERATURE <i>Maximum</i>	75°C
VELOCITY <i>Maximum</i>	600 RPM
COMMAND/SEC <i>Maximum</i>	30 units/sec
UTILIZATION VOLTAGE	18VDC to 29VDC
TORQUE	
<i>Continuous</i>	15mNm
<i>Peak</i>	30mNm

## SENSORS

### CURRENT

*Location*

1 in every actuators

### HALL EFFECT

*Location*

1 in every actuators

### ABSOLUTE POSITION

*Location*

1 in every actuators

### TEMPERATURE

*Location*

1 in every actuators

### ACCELEROMETER

*Location*

XYZ in base ( +/- 3g )

## GRIPPER

### FINGERS

*Quantity*

3

*Actuating system*

Under actuated

*Actuators*

1/finger

*Sensors*

1 current sensor/actuator

1 temperature sensor/actuator

1 hall effect sensor/actuator

*Tactile sensors*

No

## API AND SOFTWARE

API\*

*Compatibility*  
*Port*  
*Programming languages*  
*Functions*

Windows & Linux Ubuntu  
USB 2.0  
C# (C++/Mono)  
Cartesian control (speed or position)  
Angular control (speed or position)  
Data access  
General configuration  
Control configuration  
Diagnostic tools

JACOSOFT

*Compatibility*  
*Port*  
*Tools*

Windows  
USB 2.0  
General Information  
Configuration  
Protection Zones  
Trajectory  
Diagnosis

\* Please refer to the JACO API Documentation guide to get a complete description of the API functionalities.

## DIMENSIONS

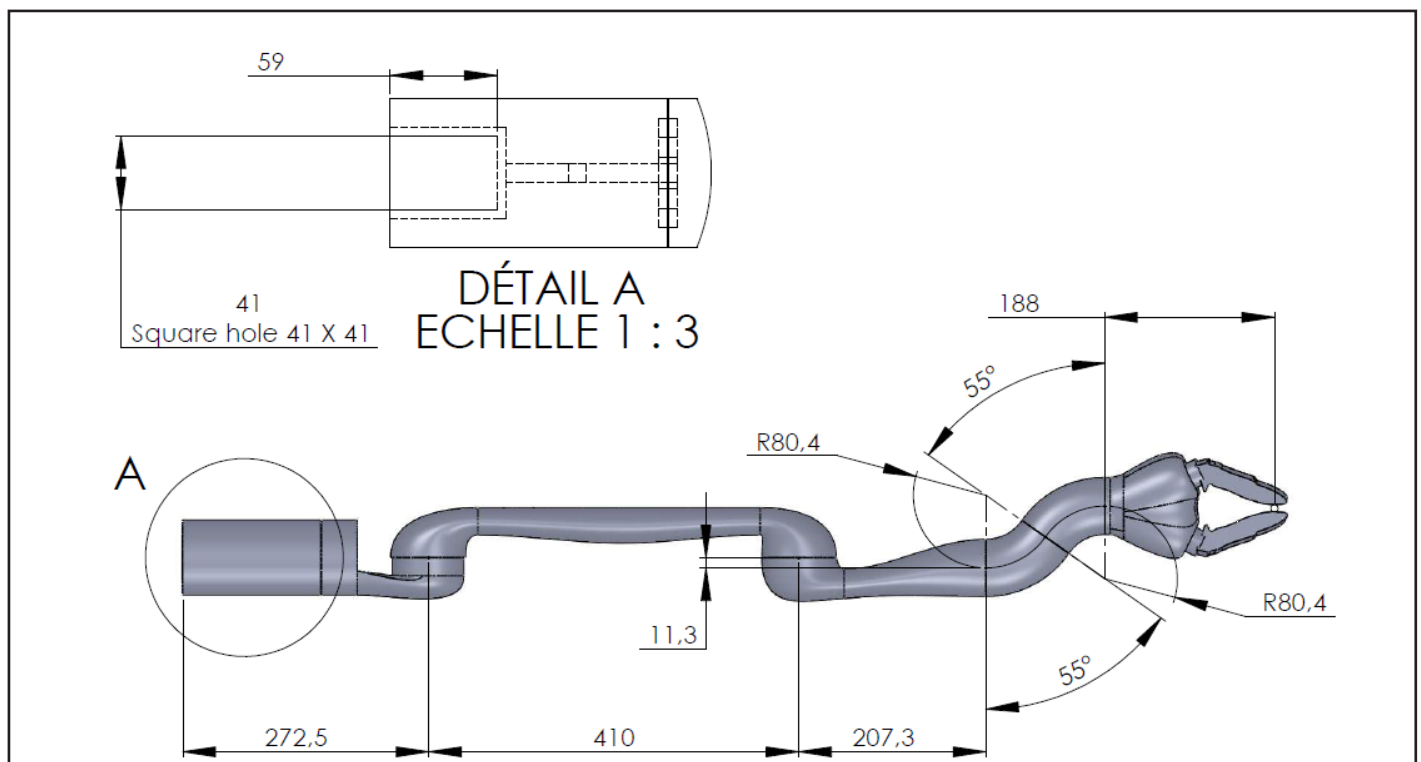



355 rue Peel #301  
Montreal (Quebec), Canada  
H3C 2G9

514-277-3777  
[info@kinovarobotics.com](mailto:info@kinovarobotics.com)